



**UTENSILI
PER TORNITURA**







CATALOGO

CLEVELAND

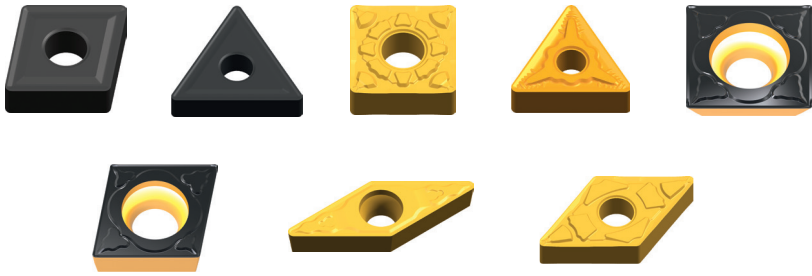
SINCE 1876

INDICE

	pagina	
Inserti per tornitura	5 ÷ 20	
Inserti per filettatura	21 ÷ 28	
Inserti per troncatura	29 ÷ 32	
Utensili per tornitura esterna	33 ÷ 46	
Utensili per tornitura interna	47 ÷ 56	
Utensili per filettatura	57 ÷ 60	
Utensili per troncatura	61 ÷ 64	



SINCE 1876

INDICE

	pag.
INSERTI PER TORNITURA	
Tabella delle applicazioni	7
Tipologie di rivestimento	7
Raccomandazioni d'uso	7
Chiave di lettura degli inserti ISO	8-9
Panoramica degli inserti negativi	10
Panoramica degli inserti positivi	11
Inserti negativi	12÷15
Inserti positivi	16÷19
INSERTI PER FILETTATURA	
Chiave di lettura degli inserti per filettatura	22
Introduzione	23
Inserti ISO metrici 60°	24-25
Inserti Whitworth	26
Inserti BSPT	27
INSERTI PER TRONCATURA	30
UTENSILI PER TORNITURA ESTERNA	
Chiave di lettura degli utensili per tornitura esterna	32
Utensili per tornitura esterna bloccaggio P-System	34÷37
Utensili per tornitura esterna bloccaggio S-System	40÷46
UTENSILI PER TORNITURA INTERNA	
Chiave di lettura degli utensili per tornitura interna	49
Utensili per tornitura interna bloccaggio S-System	52÷56
UTENSILI PER FILETTATURA	
Chiave di lettura degli utensili per filettatura	58
Utensili per filettatura esterna	59
Utensili per filettatura interna	60
UTENSILI PER TRONCATURA	
Chiave di lettura degli utensili per troncatura	62
Utensili per troncatura esterna	63
Utensili per troncatura interna	64





SINCE 1876

INSERTI per TORNITURA



TABELLA DELLE APPLICAZIONI

Pezzo	ISO	Rivestito	
		CVD	PVD
P ACCIAIO	01	TP15CB	
	10	TP15CB	
	20	TP25CB	
	30	TP25CB	
	40		
	50		
M ACCIAIO INOX	01		
	10		TM20CB
	20	TM25CG	TM14CG
	30	TM25CG	
	40		
K GHISA	01		
	10	TK15CG	
	20	TK15CG	
	30		
	40		

RIVESTIMENTO - RACCOMANDAZIONI D'USO

Pezzo	Rivestimento	Classificazione ISO	Colore superficie	Applicazioni
P	TP15CB	P10 (P05-P20)		Carburo rivestito CVD, per la finitura e la sgrossatura su acciaio e acciaio fuso. Eccellente per interruzioni di taglio leggere e alte temperature con un'ottima resistenza all'usura.
	TP25CB	P15 (P10-P25)		Carburo rivestito CVD, per semifinitura e sgrossatura su acciaio e acciaio fuso. Buono per il taglio in continuo, così come taglio interrotto.
	TP25CG	P15 (P10-P25)		Carburo rivestito CVD, adatto per semifinitura e sgrossatura media di acciai e acciai legati. Ottimo grado di resistenza all'usura e tenacità per un'ampia gamma di applicazioni.
M	TM25CG	M10 (M05-M20)		Carburo rivestito CVD, adatto per la finitura e la semifinitura di acciai inossidabili a medio spessore. Adatto per le lavorazioni in condizioni di tagli continui o leggermente interrotti.
	TM14CG	M15 (M10-M25)		Rivestito in PVD (carburo rivestito), adatto per la finitura di acciai inossidabili e resistenti al calore in sezione continua. Ottima resistenza all'usura e resistenza alla temperatura.
	TM20CB	M20 (M10-M35)		Rivestito in PVD (carburo rivestito), adatto alla semifinitura e alla finitura a velocità medio-alta di acciai inossidabili.
K	TK15CG	K10 (K05-K20)		Carburo rivestito CVD, adatto per la finitura a media lavorazione di ghisa sferoidale e ghisa grigia. Adatto per le lavorazioni in condizioni di tagli continui o leggermente interrotti.

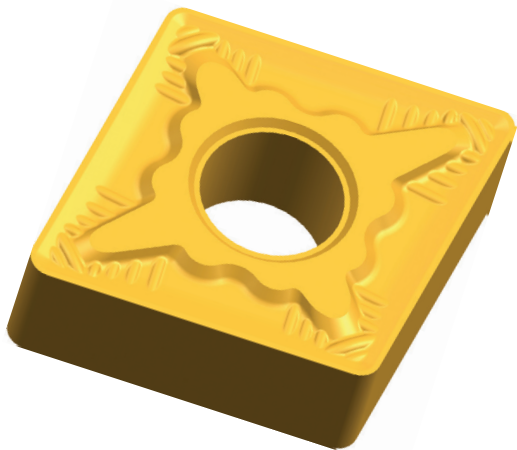
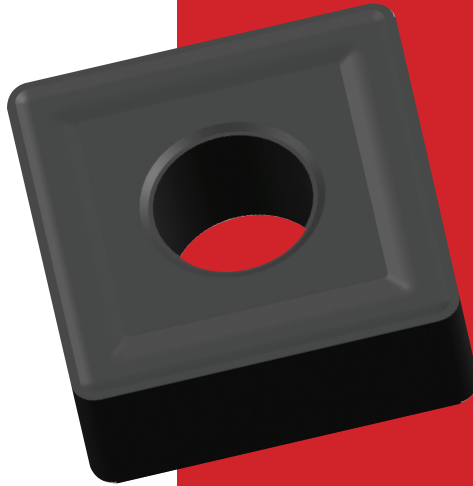
LEGENDA

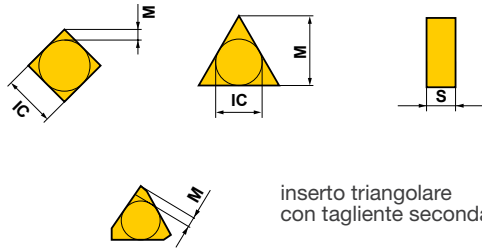

inserto triangolare con tagliente secondario

Specifiche delle tolleranze per inserti di classe M

IC	Triangolo	A spigolo	Rombici 80°	Rombici 55°	Rombici 35°	Tondo
6.35	± 0.08	± 0.08	± 0.08	± 0.11	± 0.16	-
9.525	± 0.08	± 0.08	± 0.08	± 0.11	± 0.16	-
12.70	± 0.13	± 0.13	± 0.13	± 0.15	-	-
15.875	± 0.15	± 0.15	± 0.15	± 0.18	-	-
19.05	± 0.15	± 0.15	± 0.15	± 0.18	-	-
25.40	-	± 0.18	-	-	-	-
31.75	-	± 0.20	-	-	-	-

COD.	Forma	COD.	Tolleranza altezza punta M (mm)	Tolleranza del cerchio inscritto IC (mm)	Tolleranza S (mm)
S	A spigolo	M*	± 0.08 - ± 0.18	± 0.05 - ± 0.15	± 0.13
T	Triangolare				
C	Rombici 80°				
D	Rombici 55°				
V	Rombici 35°				

• Tolleranza del cerchio inscritto (mm)

IC	Triangolo	A spigolo	Rombici 80°	Rombici 55°	Rombici 35°	Tondo
6.35	± 0.05	± 0.05	± 0.05	± 0.05	± 0.05	-
9.525	± 0.05	± 0.05	± 0.05	± 0.05	± 0.05	± 0.05
12.70	± 0.08	± 0.08	± 0.08	± 0.08	-	± 0.08
15.875	± 0.10	± 0.10	± 0.10	± 0.10	-	± 0.10
19.05	± 0.10	± 0.10	± 0.10	± 0.10	-	± 0.10
25.40	-	± 0.13	-	-	-	± 0.13
31.75	-	± 0.15	-	-	-	± 0.15

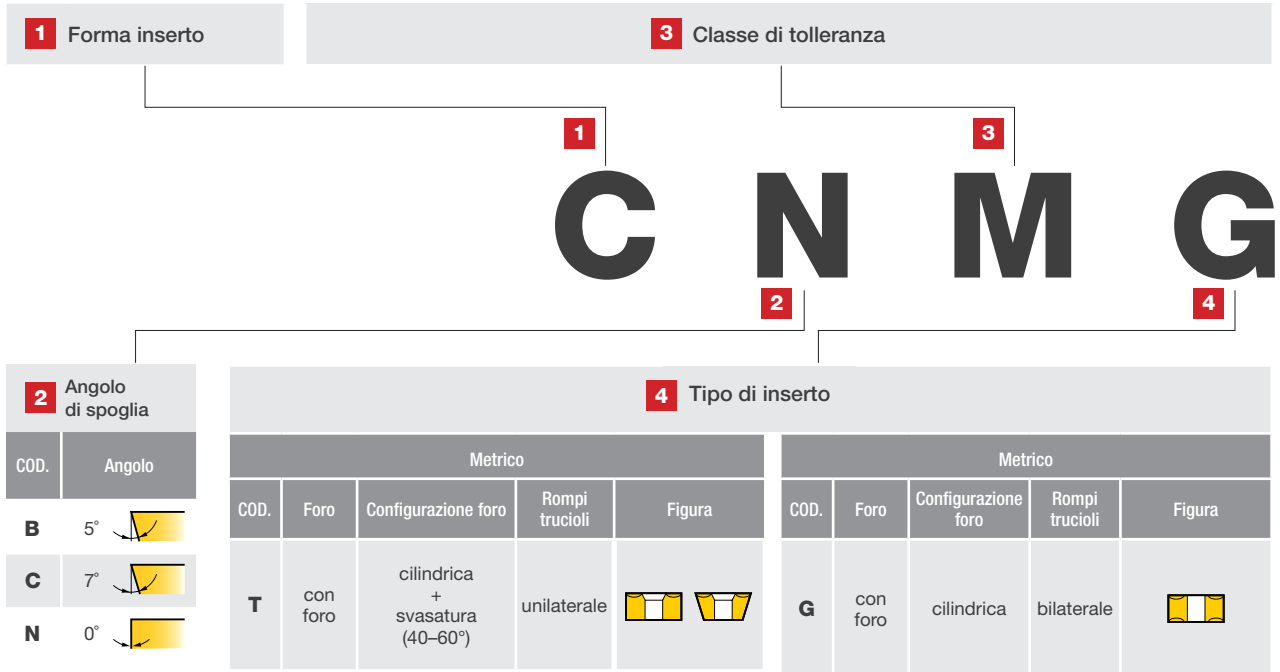

LEGENDA

Simbolo					Ø del cerchio inserito(mm)
11	07	06		11	6.35
16	11	09	09	16	9.525
	15	12	12		12.70
		16			15.875

5 Lunghezza di taglio



COD.	Spessore (mm)
02	2.38
T3	3.97
04	4.76
06	6.35

6 Spessore dell'inserto

5 **6**
12 04 08 PM

7 Raggio di punta

COD.	Raggio di punta
04	0.4
08	0.8
12	1.2
16	1.6

8 Direzione di taglio

Direzione di taglio	
Cod.	Direzione di taglio
R	Destra
L	Sinistra
N	Neutro

Condizioni di taglio

Cod.	Forma
F	Spigolo vivo
E	Spigolo arrotondato
T	Spigolo smussato
S	Spigolo arrotondato e smussato
K	Doppio smusso
P	Doppio smussato e arrotondato

INSERTI NEGATIVI - PANORAMICA

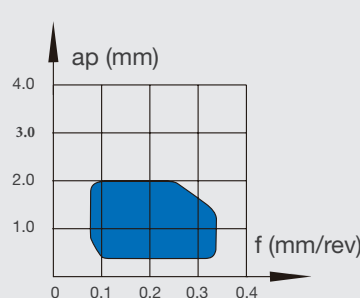
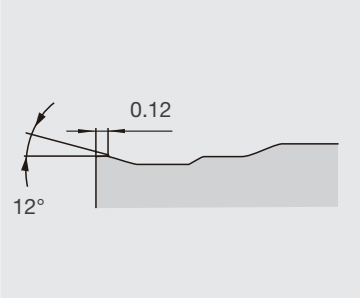
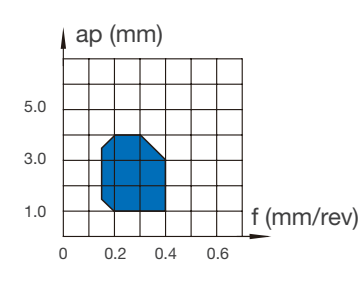
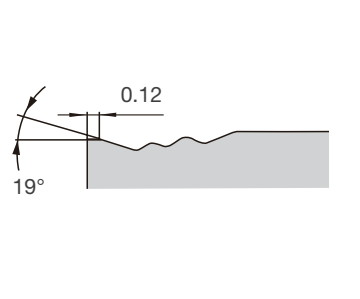
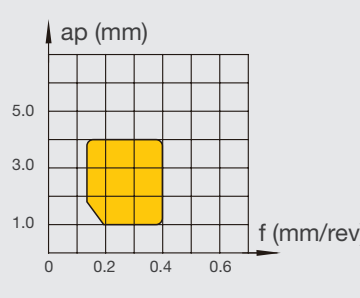
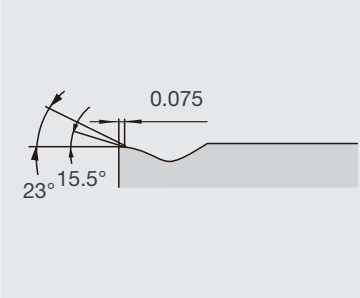
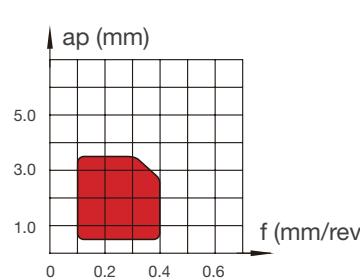
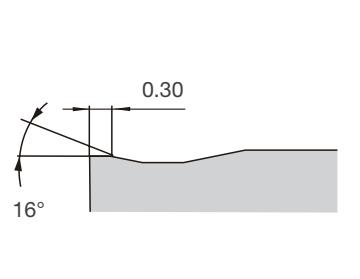
Geometria	Caratteristiche	Intervallo di elaborazione	Tagliente
PF4	Rompitruciolo speciale per la finitura di acciaio e acciai legati. Bordo ricurvo con tagliente affilato permette un buon controllo del truciolo ed una finitura superficiale fine.		
PM4	Per semi-finitura di acciaio e acciai legati. Scarico del truciolo regolare. Ampia gamma di applicazioni nella lavorazione media di acciaio e acciai legati.		
MM2	Rompitruciolo universale e tagliente affilato per lavorazioni medie di acciai inossidabili e acciaio strutturale dolce.		
KM	Rompitruciolo con tagliente affilato. Ideale per la lavorazione della ghisa anche in condizioni di taglio sfavorevoli.		

INSERTI POSITIVI - PANORAMICA

Geometria	Caratteristiche	Intervallo di elaborazione	Tagliante
PM2	Rompitruciolo con elevata stabilità del tagliante e lavorazione multiangolo per medie lavorazioni di acciaio e acciai legati. Ottimo controllo truciolo con profondità di taglio inferiori a 1 mm.		
PM7	Rompitruciolo con una vasta gamma di applicazioni nella lavorazione media di acciaio e acciai legati. Ampio angolo di spoglia ed elevata stabilità del tagliante per un controllo truciolo ottimale a basse forze di taglio.		
KM	Rompitruciolo con elevata stabilità del tagliante e lavorazione multiangolo per operazioni di medie dimensioni di ghisa, acciaio e acciai legati. Controllo del truciolo ottima grazie al grande angolo di spoglia a basse forze di taglio.		

INSERTI NEGATIVI

INSERTI NEGATIVI FINITURA TIPO CN**

K

Forma	ISO	ANSI	Rivestimento							
			P			M			K	
 80°			TP15CB	TP25CB	TP25CG	TM25CG	TM20CB	TM14CG	TK15CG	
			●	●	●	●	●	●	●	
	CNMG	120404	431							●
		120408	432							●
	 KF	160608	542							●
		160612	543							●

INSERTI NEGATIVI LAVORAZIONE MEDIA TIPO CN**

P

Forma	ISO	ANSI	Rivestimento							
			P			M			K	
 80°			TP15CB	TP25CB	TP25CG	TM25CG	TM20CB	TM14CG	TK15CG	
			●	●	●	●	●	●	●	
	CNMG	120404	431							●
		120408	432							●
	 PM4	120412	433							●
		160608	542							●
		160612	543							●

M

Forma	ISO	ANSI	Rivestimento							
			P			M			K	
 80°			TP15CB	TP25CB	TP25CG	TM25CG	TM20CB	TM14CG	TK15CG	
			●	●	●	●	●	●	●	
	CNMG	120404	431							●
		120408	432							●
	 MM2	120412	433							●
		160608	542							●
		160612	543							●
	160616	543							●	

condizioni di taglio

● taglio continuo

● taglio generico

INSERTI NEGATIVI

INSERTI NEGATIVI FINITURA TIPO DN**

P

Forma	ISO	ANSI	Rivestimento						
			P			M			K
			TP15CB	TP25CB	TP25CG	TM25CG	TM20CB	TM14CG	TK15CG
			●	●	●	●	●	●	
 DNMG PF4	110404	331		●					
	110408	332		●					
	150604	441		●					
	150608	442		●					

INSERTI NEGATIVI LAVORAZIONE MEDIA TIPO DN**

M

Forma	ISO	ANSI	Rivestimento						
			P			M			K
			TP15CB	TP25CB	TP25CG	TM25CG	TM20CB	TM14CG	TK15CG
			●	●	●	●	●	●	
 DNMG MM2	110404	331		●					
	110408	332		●					
	150604	441		●					
	150608	442		●					

K

Forma	ISO	ANSI	Rivestimento						
			P			M			K
			TP15CB	TP25CB	TP25CG	TM25CG	TM20CB	TM14CG	TK15CG
			●	●	●	●	●	●	
 DNMG KM	150604	441						●	
	150608	442						●	

condizioni di taglio

● taglio continuo ● taglio generico

INSERTI NEGATIVI

INSERTI NEGATIVI FINITURA TIPO SN**

P

Forma	ISO	ANSI	Rivestimento						
			P			M		K	
 90°			TP15CB	TP25CB	TP25CG	TM25CG	TM20CB	TM14CG	TK15CG
			●	●	●	●	●	●	●
SNMG	120404	431				●			
 PF4	120408	432				●			

INSERTI NEGATIVI LAVORAZIONE MEDIA TIPO SN**

P

Forma	ISO	ANSI	Rivestimento						
			P			M		K	
 90°			TP15CB	TP25CB	TP25CG	TM25CG	TM20CB	TM14CG	TK15CG
			●	●	●	●	●	●	●
SNMG	120408	432				●			
 PM4	120412	433				●			

INSERTI NEGATIVI LAVORAZIONE MEDIA TIPO SN**

M

Forma	ISO	ANSI	Rivestimento						
			P			M		K	
 90°			TP15CB	TP25CB	TP25CG	TM25CG	TM20CB	TM14CG	TK15CG
			●	●	●	●	●	●	●
SNMG	120408	432				●			
 MM2	120412	433				●			

K

Forma	ISO	ANSI	Rivestimento						
			P			M		K	
 90°			TP15CB	TP25CB	TP25CG	TM25CG	TM20CB	TM14CG	TK15CG
			●	●	●	●	●	●	●
SNMG	120408	432							●
 KM	120412	433							●

condizioni di taglio



taglio continuo



taglio generico

INSERTI NEGATIVI

INSERTI NEGATIVI FINITURA TIPO TN**

P

Forma	ISO	ANSI	Rivestimento						
			P			M			K
 60°			TP15CB	TP25CB	TP25CG	TM25CG	TM20CB	TM14CG	TK15CG
			●	●	●	●	●	●	●
TNMG	160404	331				●			
	160408	322				●			
 PF4									

INSERTI NEGATIVI LAVORAZIONE MEDIA TIPO TN**

P

Forma	ISO	ANSI	Rivestimento						
			P			M			K
 60°			TP15CB	TP25CB	TP25CG	TM25CG	TM20CB	TM14CG	TK15CG
			●	●	●	●	●	●	●
TNMG	160404	331				●			
	160408	322				●			
 PM4									

INSERTI NEGATIVI LAVORAZIONE MEDIA TIPO TN**

M

Forma	ISO	ANSI	Rivestimento						
			P			M			K
 60°			TP15CB	TP25CB	TP25CG	TM25CG	TM20CB	TM14CG	TK15CG
			●	●	●	●	●	●	●
TNMG	160404	331				●			
	160408	332				●			
	160412	333				●			
 MM2									

K

Forma	ISO	ANSI	Rivestimento						
			P			M			K
 60°			TP15CB	TP25CB	TP25CG	TM25CG	TM20CB	TM14CG	TK15CG
			●	●	●	●	●	●	●
TNMG	160404	331							●
	160408	332							●
	160412	333							●
 KM									



condizioni di taglio

● taglio continuo ● taglio generico

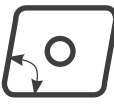

INSERTI POSITIVI

INSERTI POSITIVI LAVORAZIONE MEDIA TIPO CC**

P

Forma	ISO	ANSI	Rivestimento							
			P			M			K	
 80°			TP15CB	TP25CB	TP25CG	TM25CG	TM20CB	TM14CG	TK15CG	
			●	●	●	●	●	●	●	
	CCMT	060204	21.51							●
		060208	21.52							●
		09T304	32.51							●
		09T308	32.52							●
		120404	431							●
	120408	432							●	
 PM2										

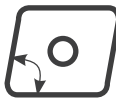
M

Forma	ISO	ANSI	Rivestimento							
			P			M			K	
 80°			TP15CB	TP25CB	TP25CG	TM25CG	TM20CB	TM14CG	TK15CG	
			●	●	●	●	●	●	●	
	CCMT	060204	21.51							●
		09T304	32.51							●
		09T308	32.52							●
		120404	431							●
		120408	432							●
 PM7										

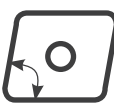
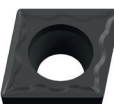

INSERTI POSITIVI LAVORAZIONE MEDIA TIPO CC**

K

Forma	ISO	ANSI	Rivestimento							
			P			M			K	
 80°			TP15CB	TP25CB	TP25CG	TM25CG	TM20CB	TM14CG	TK15CG	
			●	●	●	●	●	●	●	
	CCMT	060204	21.51							●
		060208	21.52							●
		09T304	32.51							●
		09T308	32.52							●
		120404	431							●
	120408	432							●	
 KM										

INSERTI POSITIVI FINITURA TIPO DC**

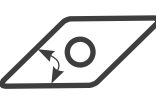
P M

Forma	ISO	ANSI	Rivestimento							
			P			M			K	
 55°			TP15CB	TP25CB	TP25CG	TM25CG	TM20CB	TM14CG	TK15CG	
			●	●	●	●	●	●	●	
	DCMT	070204	21.51							●
		11T304	32.51							●
		11T308	32.52							●
 PF7										

condizioni di taglio



● taglio continuo

● taglio generico

INSERTI POSITIVI

INSERTI POSITIVI LAVORAZIONE MEDIA TIPO DC**

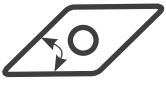
P

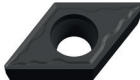

Forma	ISO	ANSI	Rivestimento						
			P			M			K
 55°			TP15CB	TP25CB	TP25CG	TM25CG	TM20CB	TM14CG	TK15CG
			●	●	●	●	●	●	●
 PM2	DCMT	070208	21.52						
		11T308	32.52						

K

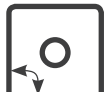

Forma	ISO	ANSI	Rivestimento						
			P			M			K
 55°			TP15CB	TP25CB	TP25CG	TM25CG	TM20CB	TM14CG	TK15CG
			●	●	●	●	●	●	●
 KM	DCMT	070204	21.51						●
		070208	21.52						●
		11T304	32.51						●
		11T308	32.52						●

INSERTI POSITIVI LAVORAZIONE MEDIA TIPO SC**

P

Forma	ISO	ANSI	Rivestimento						
			P			M			K
 90°			TP15CB	TP25CB	TP25CG	TM25CG	TM20CB	TM14CG	TK15CG
			●	●	●	●	●	●	●
 PM2	SCMT	09T304	32.51						
		09T308	32.52						
		120404	431						
		120408	432						

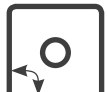
M

Forma	ISO	ANSI	Rivestimento						
			P			M			K
 90°			TP15CB	TP25CB	TP25CG	TM25CG	TM20CB	TM14CG	TK15CG
			●	●	●	●	●	●	●
 PM7	SCMT	09T304	32.51						●
		09T308	32.52						●
		120404	431						●
		120408	432						●

condizioni di taglio

● taglio continuo ● taglio generico

INSERTI POSITIVI

INSERTI POSITIVI LAVORAZIONE MEDIA TIPO SC**

K

Forma	ISO	ANSI	Rivestimento						
			P			M			K
 90°			TP15CB	TP25CB	TP25CG	TM25CG	TM20CB	TM14CG	TK15CG
			●	●	●	●	●	●	●
	SCMT	09T304	32.51						●
		09T308	32.52						●
	 KM	120404	431						●
		120408	432						●

INSERTI POSITIVI LAVORAZIONE MEDIA TIPO TC**

P M

K

Forma	ISO	ANSI	Rivestimento						
			P			M			K
 60°			TP15CB	TP25CB	TP25CG	TM25CG	TM20CB	TM14CG	TK15CG
			●	●	●	●	●	●	●
	TCMT	110204	21.51		●	●			
		110208	21.52		●	●			
	 PM2	16T304	32.51		●	●			
		16T308	32.52		●	●			
16T312		32.53		●	●				

Forma	ISO	ANSI	Rivestimento						
			P			M			K
 60°			TP15CB	TP25CB	TP25CG	TM25CG	TM20CB	TM14CG	TK15CG
			●	●	●	●	●	●	●
	TCMT	110204	21.51						●
		110208	21.52						●
	 KM	16T304	32.51						●
		16T308	32.52						●

condizioni di taglio

● taglio continuo

● taglio generico

INSERTI POSITIVI

INSERTI POSITIVI LAVORAZIONE MEDIA TIPO VB**

Forma			ISO			ANSI			Rivestimento						
									P		M		K		
									TP15CB	TP25CB	TP25CG	TM25CG	TM20CB	TM14CG	TK15CG
 35°									●	●	●	●	●	●	●
 35°									●	●	●	●	●	●	●
 PM2			VBMT 160404 32.51 160408 32.52						●						
 PM7			VBMT 160404 331 160408 332									●			

INSERTI POSITIVI LAVORAZIONE MEDIA TIPO VC**

Forma			ISO			ANSI			Rivestimento						
									P		M		K		
									TP15CB	TP25CB	TP25CG	TM25CG	TM20CB	TM14CG	TK15CG
 35°									●	●	●	●	●	●	●
 35°									●	●	●	●	●	●	●
 PM2			VCMT 160404 331 160408 332						●						
 PM7			VCMT 110304 221 110308 222 160404 331 160408 332							●		●		●	

condizioni di taglio

● taglio continuo ● taglio generico



SINCE 1876

INSERTI per FILETTATURA

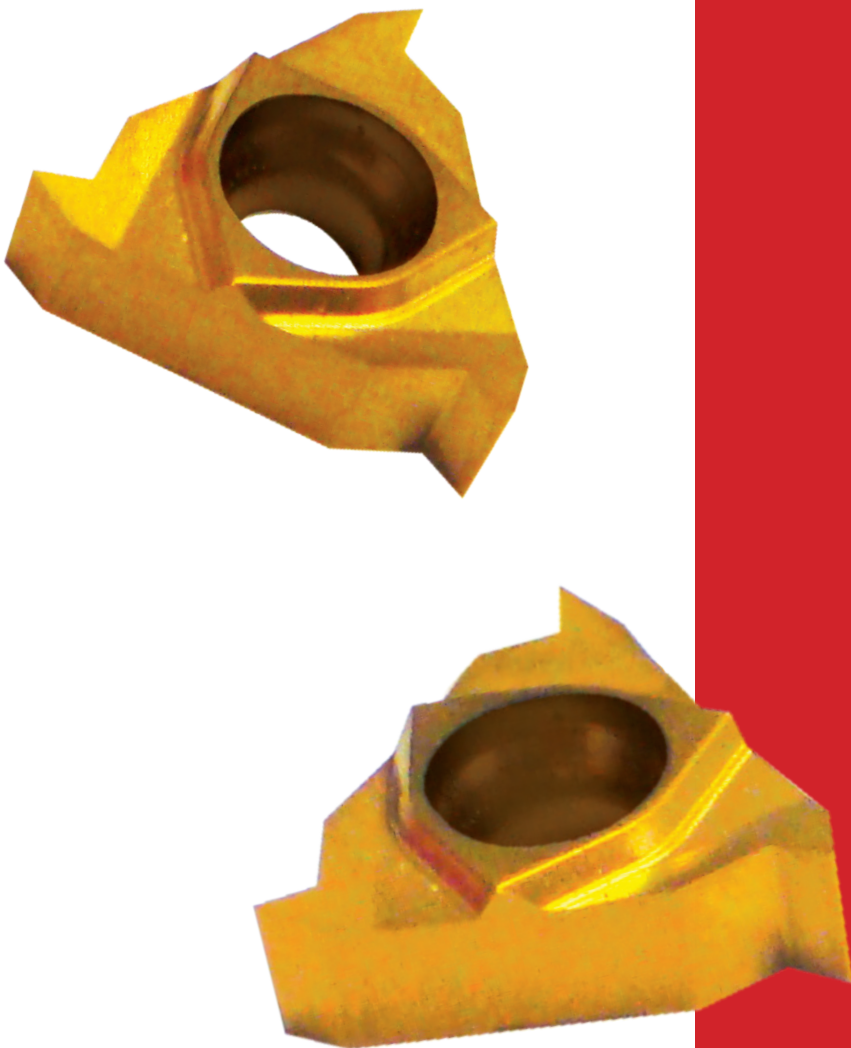

16 E R 1.50 ISO A

1

2

3

4

5

6

1 Dimensione inserto

16-IC9.525 mm

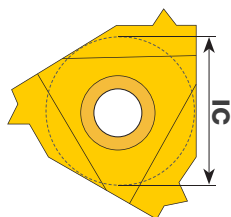

2 Tipo di lavorazione

Filettatura esterna

Filettatura interna

3 Direzione di taglio

R

Destra

L

Sinistra

4 Passo

Filettatura completa

passo mm	Tpi
0.5-6.0	48-4

Filettatura parziale

COD.	mm	Tpi
A	0.5-1.5	48-16
AG	0.5-3.0	48-8

5 Profilo filettatura

ISO metrico

Profilo 60°

Filettatura Withworth

BSPT (filettatura GAS conica)

6 Inserto filettato

A= Rompitrucciolo 3D

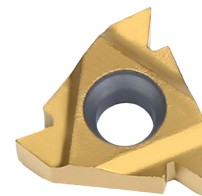



Rivestimento

TP20TA (PVD)= rivestiti TiAlN

Metallo duro con rivestimento PVD; eccellente grado di durezza, resistenza all'usura, utilizzato su acciaio e acciaio inossidabile.

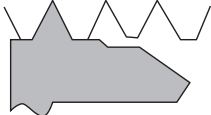
Differenze fra filettatura completa e parziale

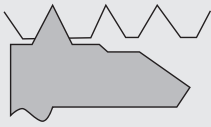
Insero filettato	Risultato	Applicazioni
<p>Filettatura completa</p> 		<ol style="list-style-type: none"> 1. Varietà completa di passi con precisione 1:1. 2. L'inserto può profilare il diametro esterno ed eliminare il processo di sbavatura.
<p>Filettatura parziale</p> 		<ol style="list-style-type: none"> 1. La superficie esterna potrebbe risultare con bave. 2. Il diametro finale delle filettature deve essere preparato prima della lavorazione. 3. L'inserto può lavorare diverse tipologie di passo (miglior rapporto costo-prestazioni).

Inseri con rompitruccioli in 3D

Insero filettato	Controllo rompitrucciolo	Precisione filettatura	Applicazioni
<p>Rompitruccioli 3D</p> 	<p>●</p>	<p>○</p>	<ol style="list-style-type: none"> 1. Alta tecnologia di precisione. 2. Migliore capacità di controllo del rompitrucciolo, maggiore durata dell'utensile.

INSERTI ISO METRICI 60°

FILETTATURA ESTERNA

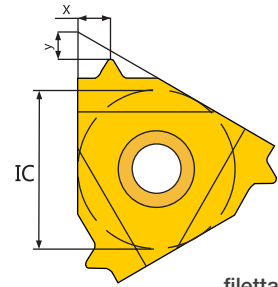
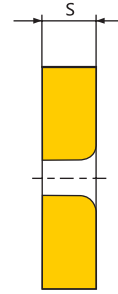
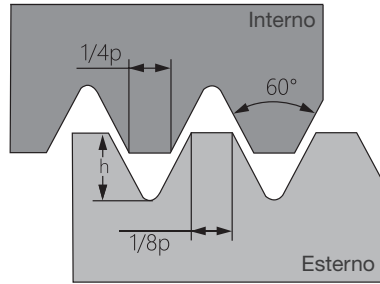

standard R262 (DIN 13)
tolleranza 6g/6H

filettatura completa

Tipo	Passo		Dimensioni				Rivestimento
	mm	Numero filetti per pollice	IC	S	X	Y	TP20TA
	16ER1.00ISOA	1.00	9.525	3.52	0.7	0.7	●
	16ER1.25ISOA	1.25	9.525	3.52	0.9	0.8	●
	16ER1.50ISOA	1.50	9.525	3.52	1.0	0.8	●
	16ER1.75ISOA	1.75	9.525	3.52	1.2	0.9	●
	16ER2.00ISOA	2.00	9.525	3.52	1.3	1.0	●
	16ER2.50ISOA	2.50	9.525	3.52	1.5	1.1	●
	16ER3.00ISOA	3.00	9.525	3.52	1.6	1.2	●

FILETTATURA INTERNA

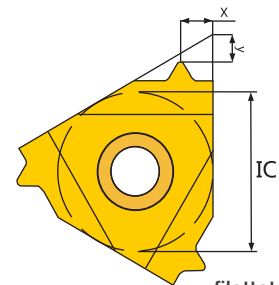
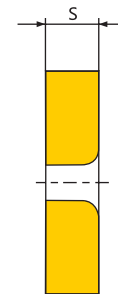
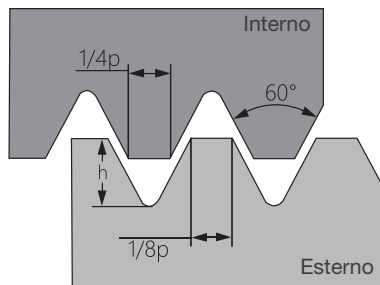

standard R262 (DIN 13)
tolleranza 6g/6H

filettatura completa

Tipo	Passo		Dimensioni				Rivestimento
	mm	Numero filetti per pollice	IC	S	X	Y	TP20TA
	16IR1.00ISOA	1.00	9.525	3.52	0.7	0.6	●
	16IR1.25ISOA	1.25	9.525	3.52	0.9	0.8	●
	16IR1.50ISOA	1.50	9.525	3.52	1.0	0.8	●
	16IR1.75ISOA	1.75	9.525	3.52	1.2	0.9	●
	16IR2.00ISOA	2.00	9.525	3.52	1.3	1.0	●
	16IR2.50ISOA	2.50	9.525	3.52	1.5	1.1	●
	16IR3.00ISOA	3.00	9.525	3.52	1.5	1.1	●

INSERTI 60° PROFILO PARZIALE

FILETTATURA ESTERNA

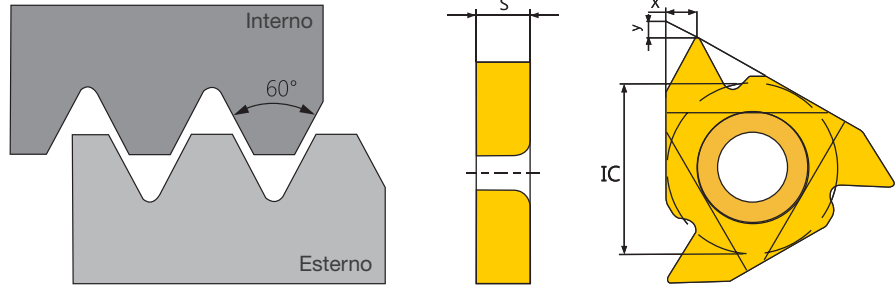

filettatura parziale

Tipo	Passo		Dimensioni				Rivestimento	
	mm	Numero filetti per pollice	IC	S	X	Y	TP20TA	
	16ERA60A	0.5 - 1.5	48 - 16	9.525	3.52	0.9	0.8	●
	16ERAG60A	0.5 - 3.0	48 - 8	9.525	3.52	1.7	1.2	●

FILETTATURA INTERNA

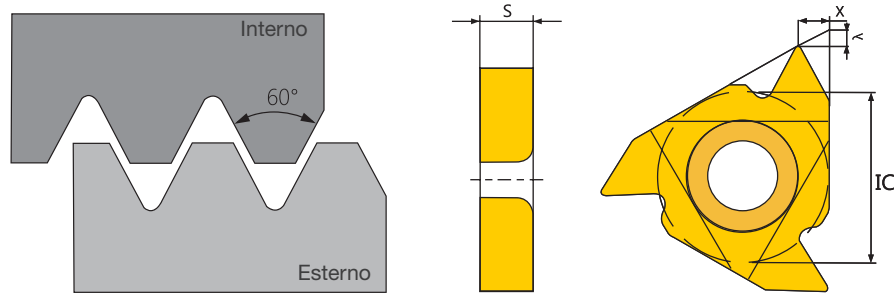

filettatura parziale

Tipo	Passo		Dimensioni				Rivestimento	
	mm	Numero filetti per pollice	IC	S	X	Y	TP20TA	
	16IRA60A	0.5 - 1.5	48 - 16	9.525	3.52	0.9	0.8	●
	16IRAG60A	0.5 - 3.0	48 - 8	9.525	3.52	1.7	1.2	●

INSERTI WHITWORTH

FILETTATURA ESTERNA

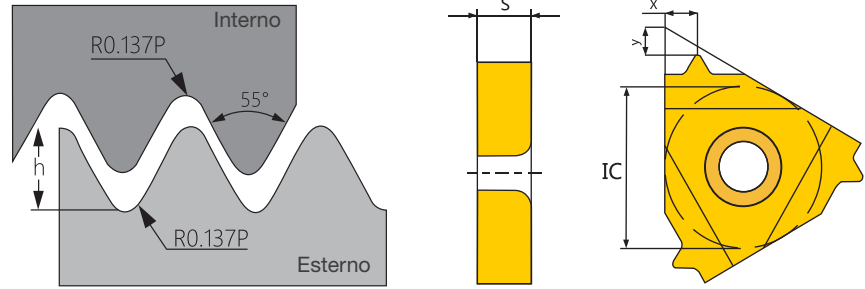

standard B.S.84 (1956); DIN 259; ISO288/1 (1982)
Classe di tolleranza A

filettatura completa

Tipo	Passo		Dimensioni				Rivestimento
	mm	Numero filetti per pollice	IC	S	X	Y	TP20TA
	16ER11WA	11	9.525	3.52	1.5	1.1	●
	16ER14WA	14	9.525	3.52	1.2	1.0	●

FILETTATURA INTERNA

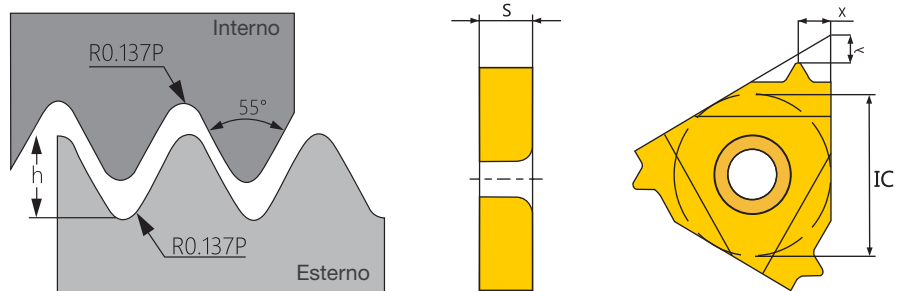

standard B.S.84 (1956); DIN 259; ISO288/1 (1982)
Classe di tolleranza A

filettatura completa

Tipo	Passo		Dimensioni				Rivestimento
	mm	Numero filetti per pollice	IC	S	X	Y	TP20TA
	16IR11WA	11	9.525	3.52	1.5	1.1	●
	16IR14WA	14	9.525	3.52	1.2	1.0	●

INSERTI BSPT

FILETTATURA ESTERNA

BSPT (inserti filettati per tubi conici standard britannici)

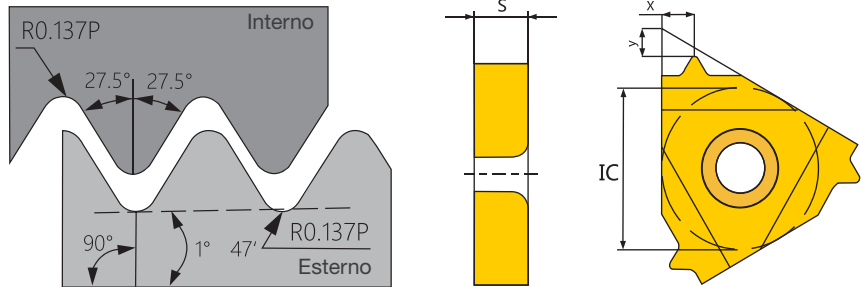

standard B.S.21 (1985)
Classe di tolleranza BSPT

filettatura completa

Tipo	Passo		Dimensioni				Rivestimento
	mm	Numero filetti per pollice	IC	S	X	Y	TP20TA
	16ER11BSPTA	11	9.525	3.52	1.5	1.1	●
	16ER14BSPTA	14	9.525	3.52	1.2	1.0	●

FILETTATURA INTERNA

BSPT (inserti filettati per tubi conici standard britannici)

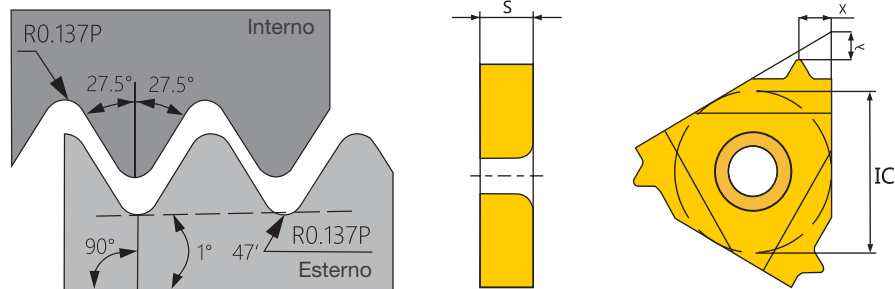

standard B.S.21 (1985)
Classe di tolleranza BSPT

filettatura completa

Tipo	Passo		Dimensioni				Rivestimento
	mm	Numero filetti per pollice	IC	S	X	Y	TP20TA
	16IR11BSPTA	11	9.525	3.52	1.5	1.1	●
	16IR14BSPTA	14	9.525	3.52	1.2	1.0	●



SINCE 1876

INSERTI per TRONCATURA

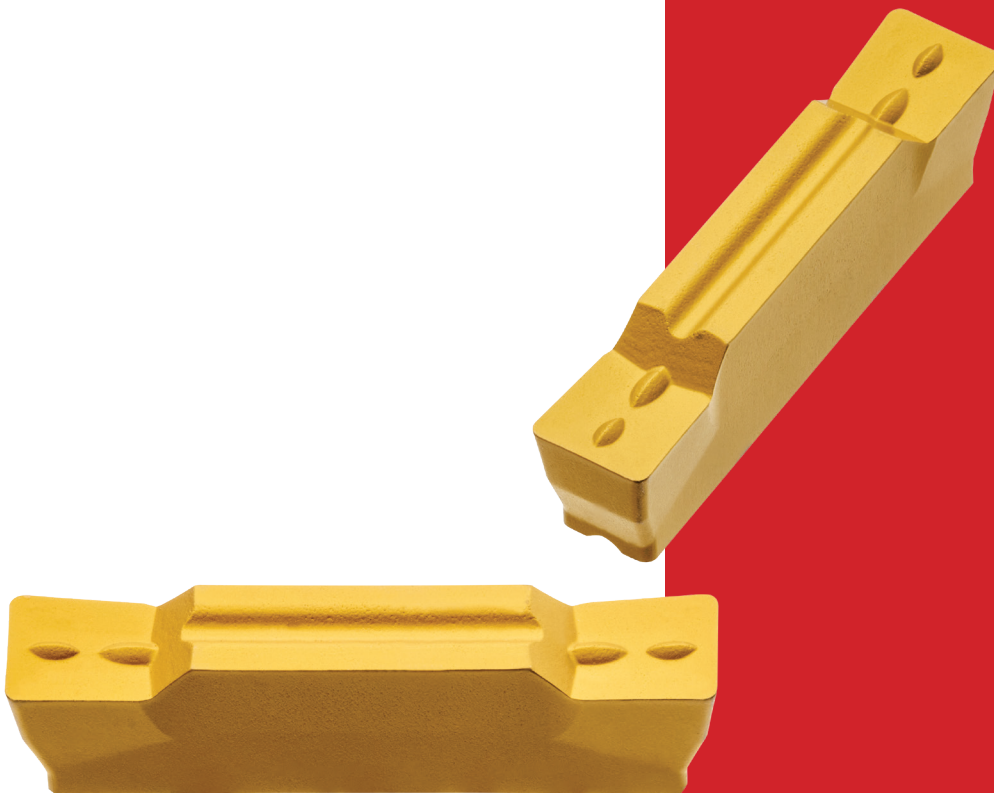

INSERTI PER TRONCATURA

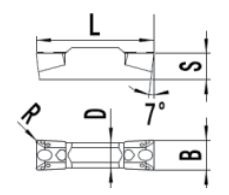
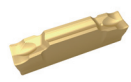
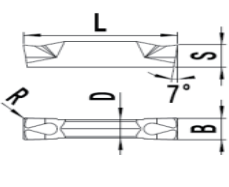
Forma		Tipo	Dimensioni (mm)					Rivestimento	
			B	R	L	D	S	CVD	
									TP25CB
		MGMN	200-M	2	0.2	16	1.2	3.5	●
			300-M	3	0.4	21	2.35	4.8	●
			400-M	4	0.4	21	3.3	4.8	●
		TDJ	2	2	0.2	20	1.7	3.9	●
			3	3	0.2	20	2.4	4	●
			4	4	0.3	19.76	3	4.05	●



LEGENDA

P S K N R

1 **2** **3** **4** **5**

1 Sistema di bloccaggio



Bloccaggio a leva Bloccaggio a vite

P **S**

2 Forma inserto



C **D** **S**



T **V**

3 Forma utensile

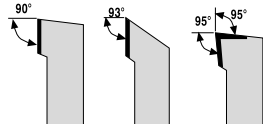

G **J** **L**

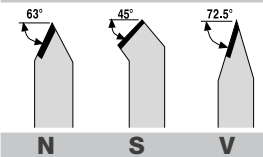

N **S** **V**

4 Angolo di spoglia inserto

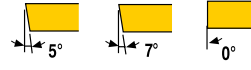

B **C** **N**

5 Direzione di taglio

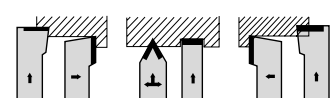

L **N** **R**

L Sinistra

N Neutro

R Destra

25 25 M 12 C

6 **7** **8** **9** **10**

6 Altezza tagliente

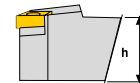

7 Larghezza gambo

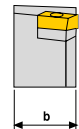

8 Lunghezza utensile

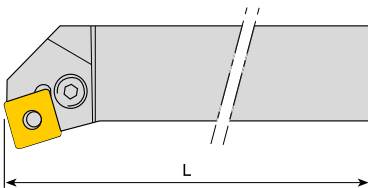

F-80 **H-100** **K-125**
M-150 **P-170**

9 Lunghezza inserto

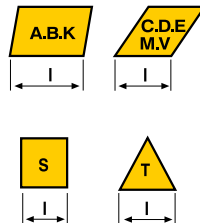

10 Bloccaggio a cuneo

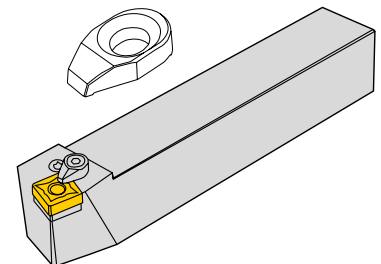



SINCE 1876

PORTAUTENSILI per TORNITURA ESTERNA BLOCCAGGIO P-SYSTEM



UTENSILI PER TORNITURA ESTERNA P-SYSTEM

PCLNR/L

95°

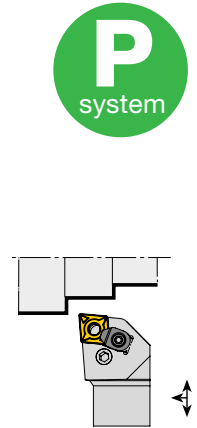
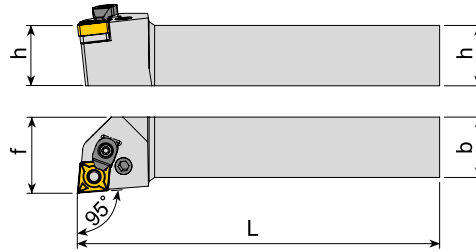
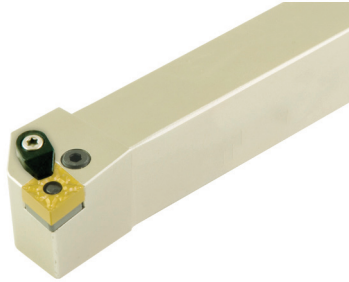

Tipo	Dimensioni				Inserti (non inclusi)	Parti di ricambio						
	h	b	L	f		Leva di fissaggio	Vite di fissaggio	Spessore	Perno dello spessore	Cuneo di fissaggio	Vite di fissaggio del cuneo	Chiave
PCLNR/L 2020 K12C	20	20	125	25	CNM.1204..							
PCLNR/L 2525 M12C	25	25	150	32	CNM.1204..							
PCLNR/L 3232 P12C	32	32	170	40	CNM.1204..							
PCLNR/L 3232 P16C	32	32	170	40	CNM.1606..							

UTENSILI PER TORNITURA ESTERNA P-SYSTEM

PDJNR/L

93°

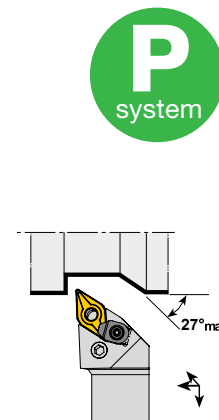
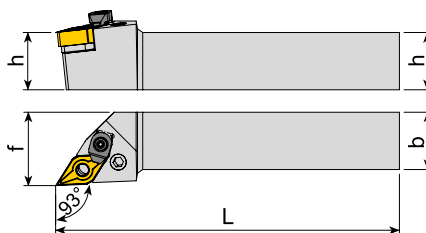
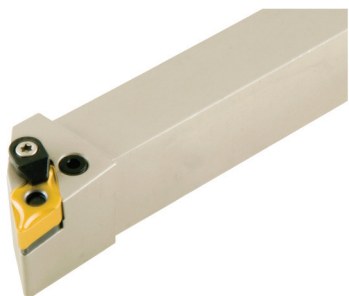

Tipo	Dimensioni				Inseri (non inclusi)	Parti di ricambio						
	h	b	L	f		Leva di fissaggio	Vite di fissaggio	Spessore	Perno dello spessore	Cuneo di fissaggio	Vite di fissaggio del cuneo	Chiave
PDJNR/L 1616 H11	16	16	100	20	DNM.1104..							
PDJNR/L 2020 K11	20	20	125	25	DNM.1104..							
PDJNR/L 2525 M11	25	25	150	32	DNM.1104..							
PDJNR/L 2020 K15C	20	20	125	25	DNM.1506..							
PDJNR/L 2525 M15C	25	25	150	32	DNM.1506..							
PDJNR/L 3232 P15C	32	32	170	40	DNM.1506..							

UTENSILI PER TORNITURA ESTERNA P-SYSTEM

PSSNR/L

45°

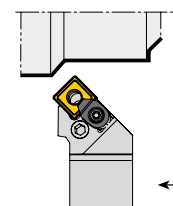
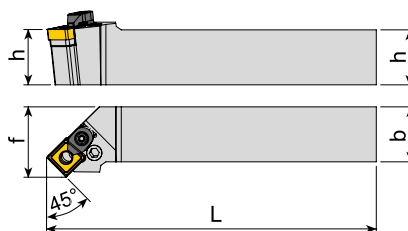
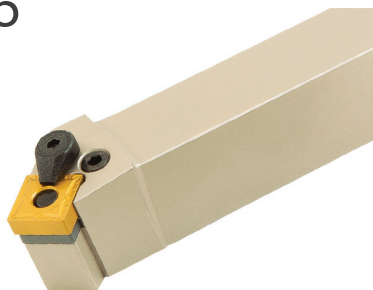

Tipo	Dimensioni				Inserti (non inclusi)	Parti di ricambio						
	h	b	L	f		Leva di fissaggio	Vite di fissaggio	Spessore	Perno dello spessore	Cuneo di fissaggio	Vite di fissaggio del cuneo	Chiave
PSSNR/L 2020 K12C	20	20	125	25	SNM.1204..							
PSSNR/L 2525 M12C	25	25	150	32	SNM.1204..							

UTENSILI PER TORNITURA ESTERNA P-SYSTEM

PTGNR/L

90°

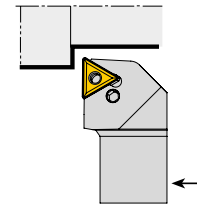
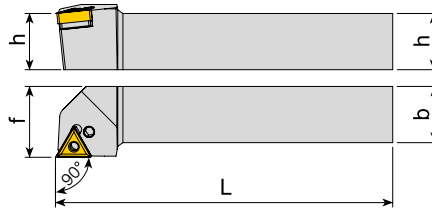
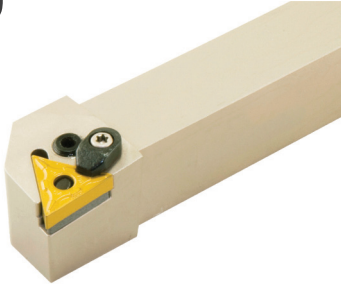

Tipo	Dimensioni				Inserti (non inclusi)	Parti di ricambio						
	h	b	L	f		Leva di fissaggio	Vite di fissaggio	Spessore	Perno dello spessore	Cuneo di fissaggio	Vite di fissaggio del cuneo	Chiave
PTGNR/L 1616 H16	16	16	100	20								
PTGNR/L 2020 K16	20	20	125	25	TNM.1604..	APL-01	ALV-02-M6 17	AATN-3-0025	AAY-01			AAL-02-2,5
PTGNR/L 2525 M16	25	25	150	32	TNM.1604..	APL-01	ALV-02-M6 17	AATN-3-0025	AAY-01			AAL-02-2,5



SINCE 1876

PORTAUTENSILI per TORNITURA ESTERNA BLOCCAGGIO S-SYSTEM



UTENSILI PER TORNITURA ESTERNA S-SYSTEM

SCLCR/L

95°

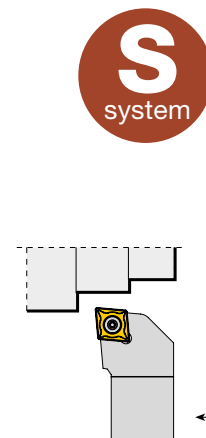
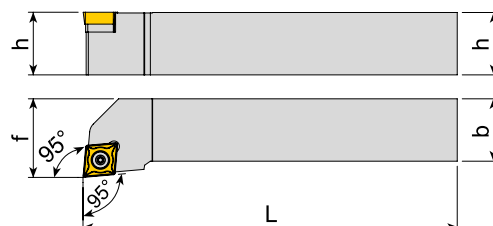
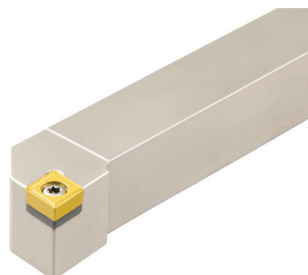

Tipo	Dimensioni				Inserti (non inclusi)	Parti di ricambio			
	h	b	L	f		Vite di fissaggio	Spessore	Vite di fissaggio dello spessore	Chiave Torx
SCLCR/L 1212 F09	12	12	80	16					
SCLCR/L 1616 H09	16	16	100	20	CCM.09T3..	4015-M3.5x11	AACN-2-0001	AAV-06-M3.5x11	80-T15
SCLCR/L 2020 K12	20	20	125	25	CCM.1204..	1020-M4.5x16	AACN-2-0003	AAV-07-M4.5x13	80-T20
SCLCR/L 2525 M12	25	25	150	32	CCM.1204..	1020-M4.5x16	AACN-2-0003	AAV-07-M4.5x13	80-T20

UTENSILI PER TORNITURA ESTERNA S-SYSTEM

SDJCR/L

93°

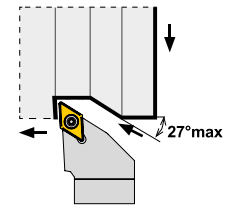
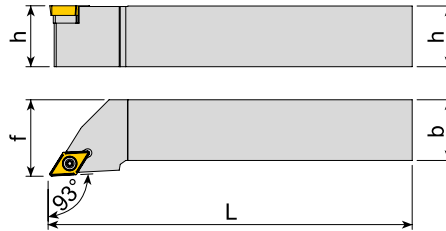
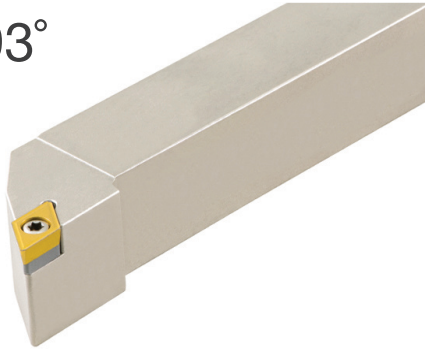

Tipo	Dimensioni				Inserti (non inclusi)	Parti di ricambio			
	h	b	L	f		Vite di fissaggio	Spessore	Vite di fissaggio dello spessore	Chiave Torx
SDJCR/L 1212 F07	12	12	80	16					
SDJCR/L 1616 H07	16	16	100	20	DCM.0702..	4008-M2.5x6			80-T08
SDJCR/L 2020 K11	20	20	125	25	DCM.11T3..	4015-M3.5x14	AADN-2-0001	AAV-06-M3.5x11	80-T15
SDJCR/L 2525 M11	25	25	150	32	DCM.11T3..	4015-M3.5x14	AADN-2-0001	AAV-06-M3.5x11	80-T15

UTENSILI PER TORNITURA ESTERNA S-SYSTEM

SDNCN

62.5°

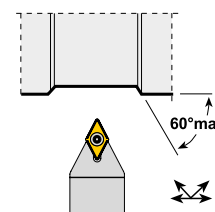
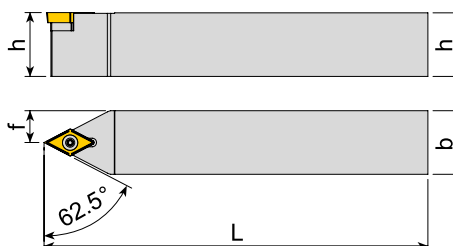
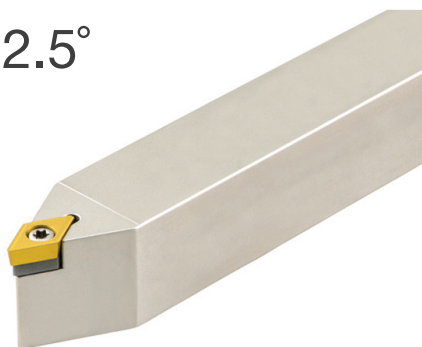

Tipo	Dimensioni				Inseriti (non inclusi)	Parti di ricambio			
	h	b	L	f		Vite di fissaggio	Spessore	Vite di fissaggio dello spessore	Chiave Torx
SDNCN 1616 H11	16	16	100	20					
SDNCN 2020 K11	20	20	125	25	DCM.11T3..	4015-M3.5x14	AADN-2-0001	AAV-06-M3.5x11	80-T15

UTENSILI PER TORNITURA ESTERNA S-SYSTEM

SSSCR/L

45°

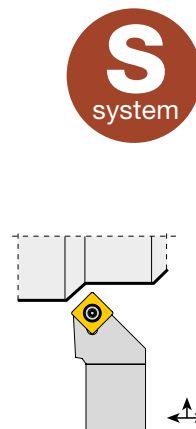
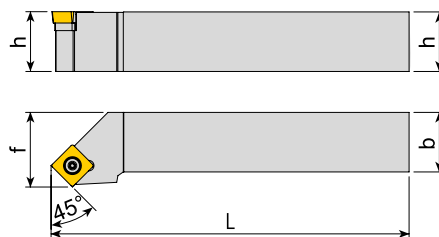

Tipo	Dimensioni				Inserti (non inclusi)	Parti di ricambio			
	h	b	L	f		Vite di fissaggio	Spessore	Vite di fissaggio dello spessore	Chiave Torx
SSSCR/L 1212 F09	12	12	80	16					
SSSCR/L 1616 H09	16	16	100	20	SC.T09T3..	4015-M3.5x14	AASN-2-0001	AAV-06-M3.5x11	80-T15
SSSCR/L 2020 K12	20	20	125	25	SC.T1204..	1020-M4.5x16	AASN-2-0004	AAV-07-M4.5x13	80-T20
SSSCR/L 2525 M12	25	25	150	32	SC.T1204..	1020-M4.5x16	AASN-2-0004	AAV-07-M4.5x13	80-T20

UTENSILI PER TORNITURA ESTERNA S-SYSTEM

STGCR/L

90°

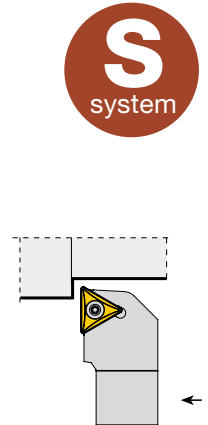
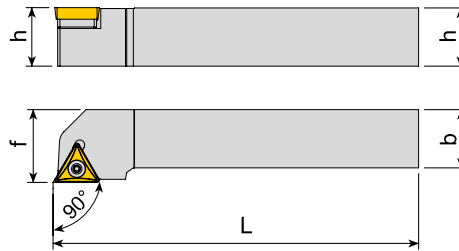
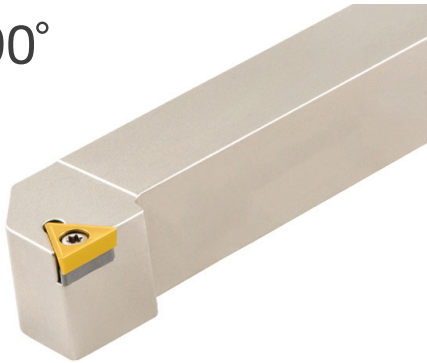

Tipo	Dimensioni				Inserti (non inclusi)	Parti di ricambio			
	h	b	L	f		Vite di fissaggio	Spessore	Vite di fissaggio dello spessore	Chiave Torx
STGCR/L 1616 H11	16	16	100	20					
STGCR/L 2020 K16	20	20	125	25	TC.T 1102..	4008-M2.5x6	AATN-2-0001	AAV-06-M3.5x11	80-T08
STGCR/L 2525 M16	25	25	150	32	TC.T 16T3..	4015-M3.5x14	AATN-2-0001	AAV-06-M3.5x11	80-T15

UTENSILI PER TORNITURA ESTERNA S-SYSTEM

SVJCR/L

93°

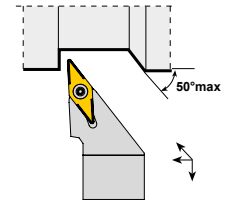
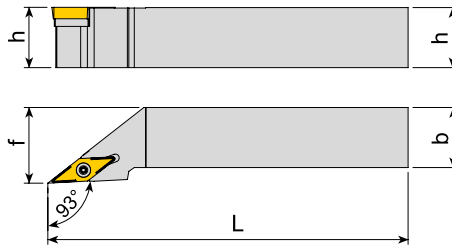
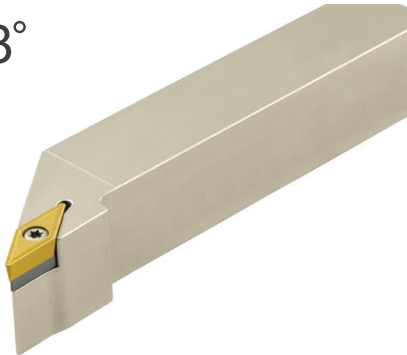

Tipo	Dimensioni				Inserti (non inclusi)	Parti di ricambio			
	h	b	L	f		Vite di fissaggio	Spessore	Vite di fissaggio dello spessore	Chiave Torx
SVJCR/L 1616 H11	16	16	100	20					
SVJCR/L 2020 K16	20	20	125	25	VC.T 1604..	4015-M3.5x14	AAVN-2-0002	AAV-06-M3.5x11	80-T15
SVJCR/L 2525 M16	25	25	150	32	VC.T 1604..	4015-M3.5x14	AAVN-2-0002	AAV-06-M3.5x11	80-T15

UTENSILI PER TORNITURA ESTERNA S-SYSTEM

SVBN

72.5°

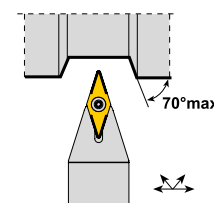
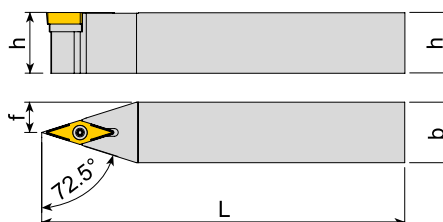

Tipo	Dimensioni				Inserti (non inclusi)	Parti di ricambio			
	h	b	L	f		Vite di fissaggio	Spessore	Vite di fissaggio dello spessore	Chiave Torx
SVBN 2020 K16	20	20	125	10					
SVBN 2525 M16	25	25	150	12,5	VBM. 1604..	4015-M3.5x14	AAVN-2-0002	AAV-06-M3.5x11	80-T15

Articoli a richiesta



SINCE 1876

PORTAUTENSILI per TORNITURA INTERNA



LEGENDA

S 25 S P C L N R 12 C

1 2 3 4 5 6 7 8 9 10

1 Tipo di gambo

„S“ Gambo in acciaio

4 Sistema di bloccaggio

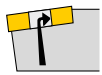

Bloccaggio a leva

P

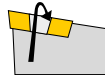

Bloccaggio a vite

S

2 Diametro del gambo

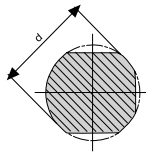

3 Lunghezza utensile

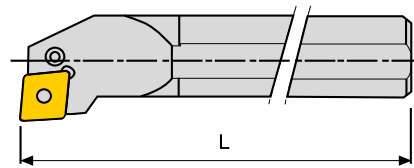

H-100

K-125

P-170

x-special
(mm)

R-200

S-250

T-300

5 Forma inserto



C

D

T

6 Forma utensile

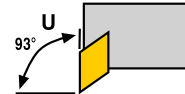
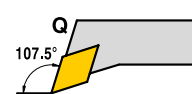
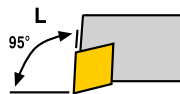
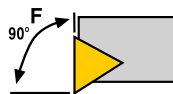

7 Angolo di spoglia inserto

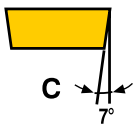

C

8 Direzione di taglio

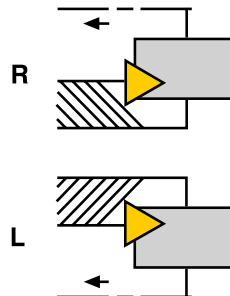

R Destra

L Sinistra

9 Dimensioni inserto

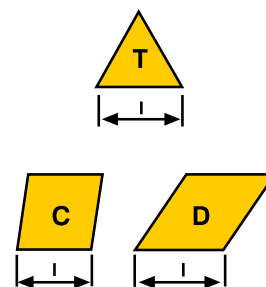

10 Bloccaggio a cuneo

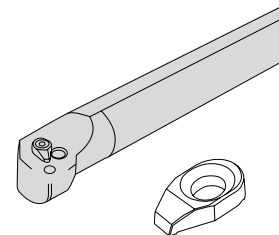



SINCE 1876

**PORTAUTENSILI
per TORNITURA
INTERNA
BLOCCAGGIO
S-SYSTEM**



UTENSILI PER TORNITURA INTERNA S-SYSTEM

SCFCR/L

90°

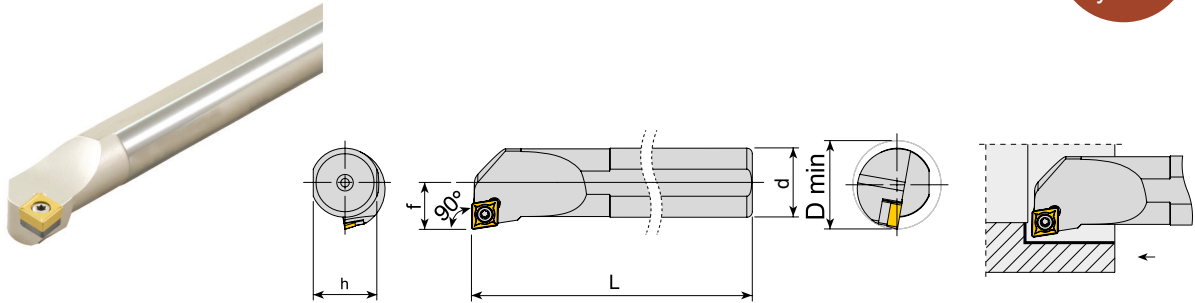

Tipo	Dimensioni					Inseri (non inclusi)	Parti di ricambio			
	d	h	L	f	D _{min}		Vite di fissaggio	Spessore	Vite di fissaggio dello spessore	Chiave Torx
S08H SCFCR/L 06	8	7.3	100	06	≥11					
S10K SCFCR/L 06	10	9	125	7	≥13					
S12K SCFCR/L 06	12	11	125	9	≥16					
S16P SCFCR/L 09	16	14.8	170	11	≥20					
S20R SCFCR/L 09	20	18.3	200	13	≥25					

UTENSILI PER TORNITURA INTERNA S-SYSTEM

SCLCR/L

95°

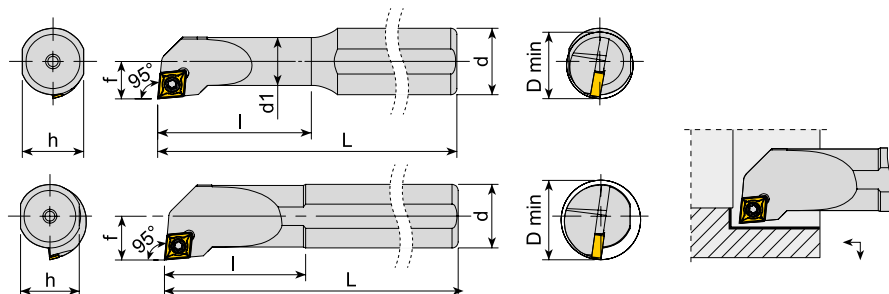
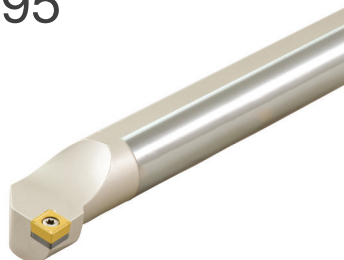

Tipo	Dimensioni							Inserti (non inclusi)	Parti di ricambio			
	d	d1	h	l	L	f	D _{min}		Vite di fissaggio	Spessore	Vite di fissaggio dello spessore	Chiave Torx
S08H SCLCR/L 06	8	8	7.3	20	100	6	≥11		4008-M2.5x6			80-T08
S10K SCLCR/L 06	10	10	09	25	125	07	≥13		4008-M2.5x6			80-T08
S12K SCLCR/L 06	12	12	11	25	125	09	≥16		4008-M2.5x6			80-T08
S16P SCLCR/L 09	16	16	14.8	35	170	11	≥20		4015-M3.5x9			80-T15
S20R SCLCR/L 09	20	20	18.3	40	200	13	≥25		4015-M3.5x9			80-T15
S25S SCLCR/L 12	25	25	23	50	250	17	≥32		4020-M4.5x12	AACN-2-0003	AAV-10-M4.5x8	80-T20
S32T SCLCR/L 12	32	32	30	60	300	22	≥40		4020-M4.5x12	AACN-2-0003	AAV-10-M4.5x8	80-T20

UTENSILI PER TORNITURA INTERNA S-SYSTEM

SDQCR/L

107.5°

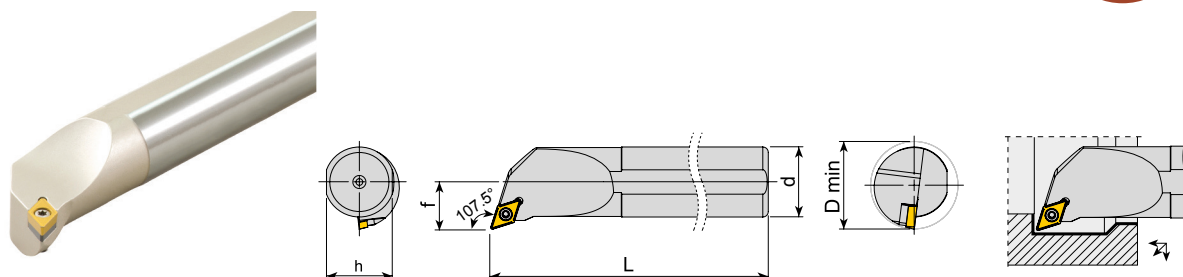

Tipo	Dimensioni					Inserti (non inclusi)	Parti di ricambio			
	d	h	L	f	D _{min}		Vite di fissaggio	Spessore	Vite di fissaggio dello spessore	Chiave Torx
S10K SDQCR/L 07	10	09	125	07	≥13					
S12K SDQCR/L 07	12	11	125	09	≥16					
S16P SDQCR/L 07	16	14.8	170	11	≥20					
S20R SDQCR/L 11	20	18.3	200	13	≥25					
S25S SDQCR/L 11	25	23	250	17	≥32			AADN-2-0001	AAV-08-M3.5x8	
S32T SDQCR/L 11	32	30	300	22	≥40			AADN-2-0001	AAV-06-M3.5x11	

UTENSILI PER TORNITURA INTERNA S-SYSTEM

SDUCR/L

93°

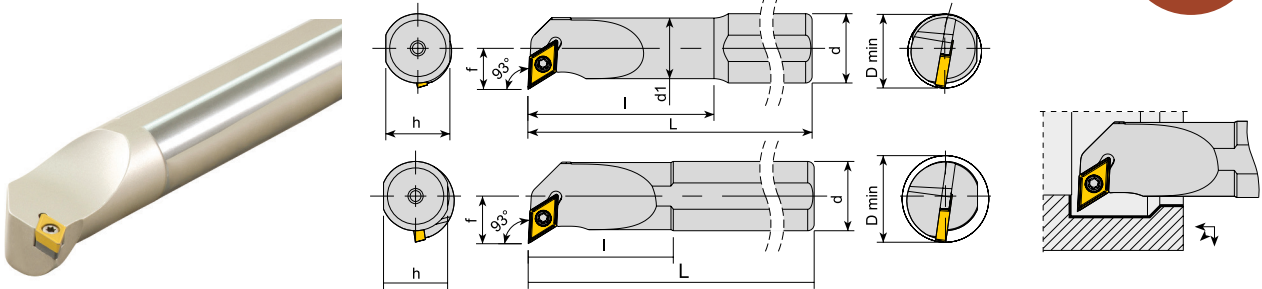

Tipo	Dimensioni							Inserti (non inclusi)	Parti di ricambio			
	d	d1	h	l	L	f	D _{min}		Vite di fissaggio	Spessore	Vite di fissaggio dello spessore	Chiave Torx
S10K SDUCR/L 07	10	10	09	25	125	08	≥13		4008-M2.5x6			80-T08
S12K SDUCR/L 07	12	12	11	25	125	09	≥16		4008-M2.5x6			80-T08
S16P SDUCR/L 07	16	16	14.8	35	170	11	≥20		4008-M2.5x6			80-T08
S20R SDUCR/L 11	20	20	18.3	40	200	13	≥25		4015-M3.5x11			80-T15
S25S SDUCR/L 11	25	25	23	50	250	17	≥32		4015-M3.5x14	AADN-2-0001	AAV-08-M3.5x8	80-T15
S32T SDUCR/L 11	32	32	30	60	300	22	≥40		4015-M3.5x14	AADN-2-0001	AAV-06-M3.5x11	80-T15

UTENSILI PER TORNITURA INTERNA S-SYSTEM

STFCR/L

90°

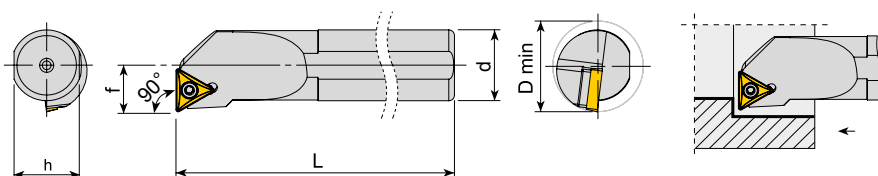

Tipo	Dimensioni					Inserti (non inclusi)	Parti di ricambio			
	d	h	L	f	D _{min}		Vite di fissaggio	Spessore	Vite di fissaggio dello spessore	Chiave Torx
S12K STFCR/L 11	12	11	125	09	≥17					80-T08
S16P STFCR/L 11	16	14.8	170	11	≥20					80-T08
S20R STFCR/L 16	20	18.3	200	13	≥25					80-T15
S25S STFCR/L 16	25	23	250	17	≥32			AATN-2-0001	AAV-08-M3.5x8	80-T15
S32T STFCR/L 16	32	30	300	22	≥40			AATN-2-0001	AAV-06-M3.5x11	80-T15



SINCE 1876

UTENSILI per FILETTATURA



LEGENDA

S E R 25 25 M 16 C

1

2

3

4

5

6

7

8

1 Sistema di bloccaggio

„S“ Bloccaggio a vite

2 Tipo di lavorazione

„E“ Filettatura esterna
„I“ Filettatura interna

3 Esecuzione

„R“ destra
„L“ sinistra

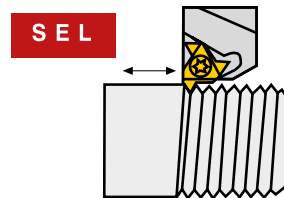
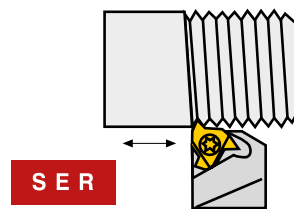

4 5 Sistema di bloccaggio

gambo:
h x b 2525 x 25 x 25 mm

5 Diametro gambo

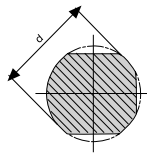

6 Lunghezza utensile

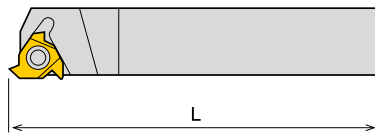

H-100	K-125	M-150	x-special (mm)
P-170	R-200		

7 Dimensioni inserto

l (mm)	d
16	3/8

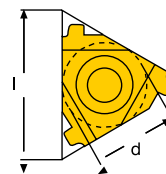

8 Bloccaggio a cuneo

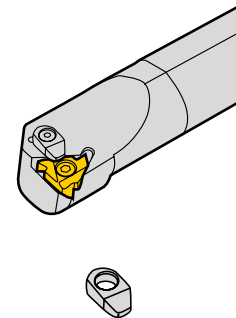

S I R S 25 R 16 C

1

2

3

4

5

6

7

8

UTENSILI PER FILETTATURA ESTERNA

SER/L

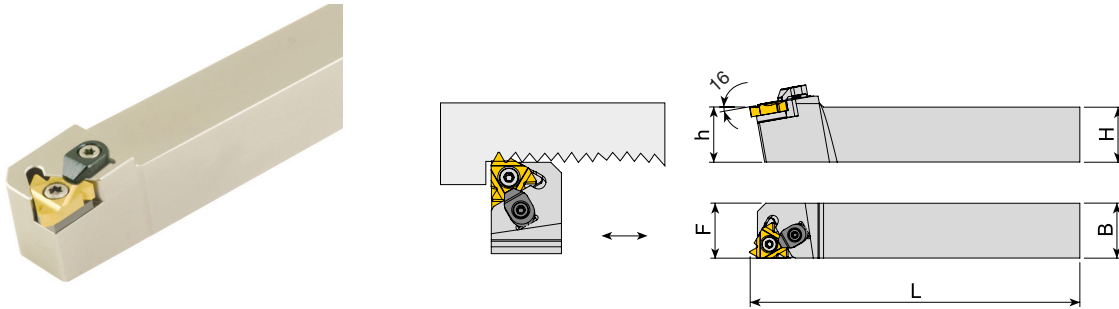

Tipo	Dimensioni				Inserti (non inclusi)	Parti di ricambio					
	h=H	B	L	F		Vite di fissaggio	Spessore	Vite di fissaggio dello spessore	Cuneo di fissaggio	Vite di fissaggio del cuneo	Chiave Torx
SER/L 1616 H16C	16	16	100	16	 16 ER/EL (0.35 - 3) ISO METRIC						
SER/L 2020 K16C	20	20	125	20							
SER/L 2525 M16C	25	25	150	25							

UTENSILI PER FILETTATURA INTERNA

SIR/L

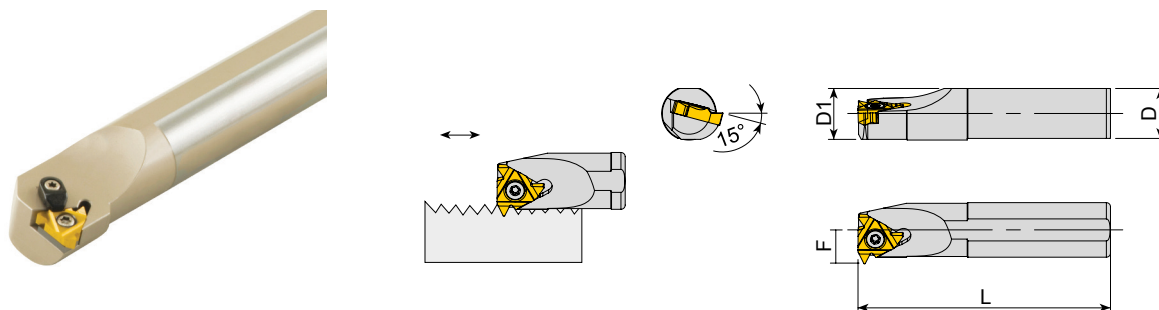

Tipo	Dimensioni					Inseri (non inclusi)	Parti di ricambio					
	D	D1	L	F	D _{min}		Vite di fissaggio	Spessore	Vite di fissaggio dello spessore	Cuneo di fissaggio	Vite di fissaggio del cuneo	Chiave Torx
SIR/L S16M 16	16	16	150	11.7	19	 16 IR/L (0.35 - 3) ISO METRIC						80-T15
SIR/L S20P 16	20	20	170	13.7	24							80-T15
SIR/L S25R16C	25	25	200	16.2	29							80-T15



SINCE 1876

PORTAUTENSILI per TRONCATURA



LEGENDA

A DKT - K - R - 2525

1

2

3

4

5

100 - 150 - 4 - T22

6

7

8

2 Tagliante

DKT: troncatura esterna
IKT: troncatura interna

3 Tipo di inserti

MGM
TD

4 Esecuzione

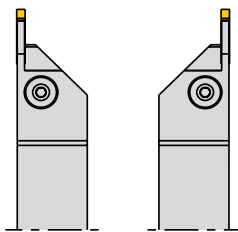

R

L

R

Destra

L

Sinistra

5 Altezza tagliente e larghezza gambo

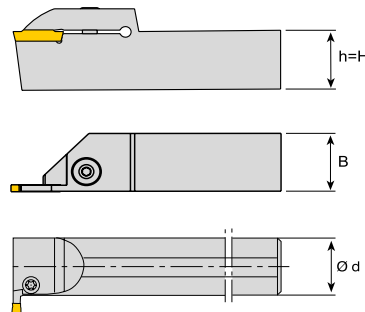

6 Diametro di taglio

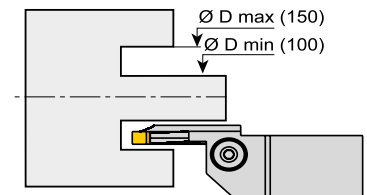

7 Larghezza tagliente

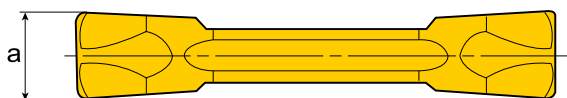

a

2=2.0 mm

3=3.0 mm

4=4.0 mm



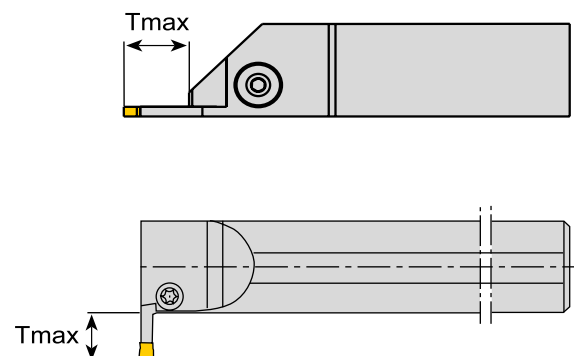

8 Profondità di taglio

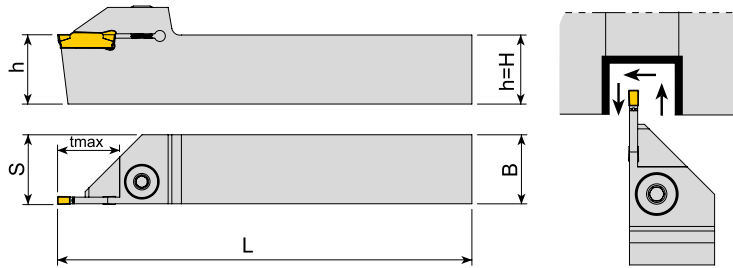
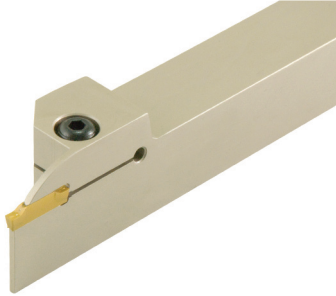

UTENSILI PER TRONCATURA ESTERNA

ADKT-TD-R/L





Tipo	Dimensioni					Inseri (non inclusi)	Parti di ricambio			
	h=H	B	L	S	t _{max}		Vite di fissaggio	Rondella	Chiave	
ADKT-TD-R/L-1212-2-T15	12	12	100	16.3	15					
ADKT-TD-R/L-1616-2-T15	16	16	125	16.3	15		TD. - 2	AKV-02-M6x22	ABPL-01	AAL-03-3
ADKT-TD-R/L-2020-2-T15	20	20	125	20.3	15		AKV-02-M6x22	ABPL-01	AAL-03-3	
ADKT-TD-R/L-2020-3-T20	20	20	125	20.4	20	TD. - 3	2004-M8x1x20		AAL-05-4	
ADKT-TD-R/L-2525-3-T9	25	25	150	25.4	9		2004-M8x1x20		AAL-05-4	
ADKT-TD-R/L-2525-4-T22	25	25	150	25.5	22		TD. - 4	2004-M8x1x20		AAL-05-4

UTENSILI PER TRONCATURA INTERNA

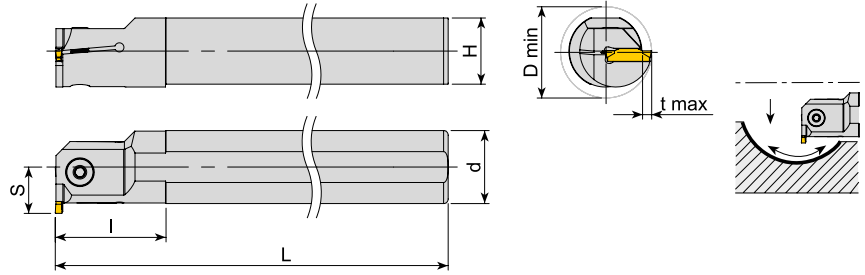
AIKT-K-R/L



Tipo	Dimensioni							Inserti (non inclusi)	Parti di ricambio	
	d	D _{min}	L	l	t _{max}	H	S		Vite di fissaggio	Chiave
AIKT-K-R/L-16-2-T4	16	21	150	28	4	14.8	12	 MGM. - 2	2503-M4x10	AAL-03-3
AIKT-K-R/L-20-2-T4	20	25	170	30	4	18.3	14		2503-M4x12	AAL-03-3
AIKT-K-R/L-25-2-T6	25	32	200	40	6	23	18.5		2504-M5x12	AAL-05-4
AIKT-K-R/L-20-4-T6	20	27	170	30	6	18.3	16	 MGM. - 4	2504-M5x12	AAL-05-4
AIKT-K-R/L-25-4-T10	25	32	200	49	10	23	17		2504-M5x16	AAL-05-4